

FEATURES

- Fast Microsecond Processing
- Prewired M-12 Connectors
- Magnetic Base Mount
- 2 - Lines of 16 Character Digital Display
- Single Dial/Push Button Control
- On-board MD-1 Mini Driver on Channel 1
 - For High-speed 6-volt coils
- 24DC or 120AC Output Relays on Channels 1 & 2, where applicable

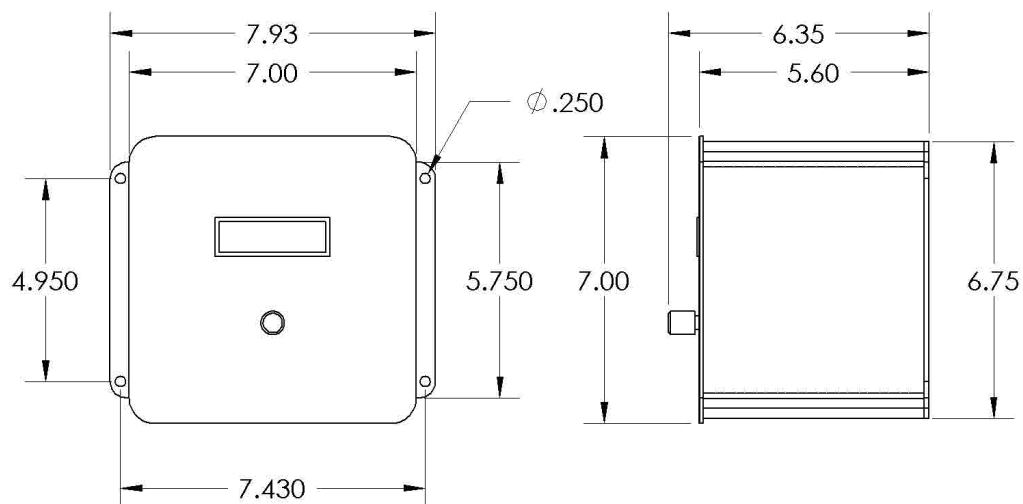

Specifications

POWER

120 VAC 5 amp fused

24 VDC 1.8 amp internal power supply. (1.6 amp max. available to power input and output devices)

INPUTS

Encoder Input: 24 vdc, 100 kHz max frequency

Product Presence Sensor #1: 24 VDC, PNP

Product Presence Sensor #2: 24 VDC, PNP

OUTPUTS

Output #1: PWM driver, pull in and hold programmable 12-32 VDC 2 amp peak current, 1 amp continuous

Output #1: Solid state relay 24 VDC 3 amp max, or optional 120 VAC

Output #2: Solid state relay 24 VDC 3 amp max, or optional 120 VAC

PERFORMANCE

Resolution of 100 microsecond (0.1 msec)

Valve mechanical response compensation for precise glue pattern registration

Low speed cut-off adjustable (1fpm-99fpm)

Dots guaranteed at beginning and end of patterns regardless of spacing settings

20 Program storage and program re-call

Auto dot capability with max adjustable speed setting to auto switch to line/flow control mode

Output disable/enable setting for each web break input

Versions: -A adds 0-10 VDC analog output for gear-line speed signal

-FC adds pneumatic transducer to operate air piloted flow regulators

NON-STANDARD ITEMS (PRICE ADDER)

Power: 240 VAC 2.5 amps

Inputs: NPN

Outputs: 240 VAC

Daisy chainable for wiring multiple controls together for increased I/O applications

Custom programming available to meet your specific application



6504 Snider Road Loveland, OH 45140 800-852-3522

www.haeco.us